

HOBART701 S Ridge Avenue, Troy, OH 45374
1-888-4HOBART • www.hobartcorp.com**WP-6
WATERPRESS****HOBART****STANDARD FEATURES**

- Reduces waste volume up to 88%.
- Appropriate to handle foodservice waste from schools, hospitals, clubs, fast food service, commercial restaurants, commissaries, airline-in-flight kitchens, or confidential document destruction.
- Squeezes waste slurry, returns water to pulper for re-use, discharges a semi-dry pulp.
- Stainless steel screw, screen and housing.
- 6" diameter gear-driven helical screw with attached nylon brush mounted within perforated cylindrical screen.
- Helical screw and screen assembly removable without disconnecting slurry or return water piping.
- Stainless steel wiper plates control pulp moisture content.
- Chemical pump standard.
- Stainless steel, removable access covers.
- 3 H.P. foot-mounted, totally enclosed, fan-cooled waterpress motor.
- 5 H.P. foot-mounted, totally enclosed, fan-cooled return pump motor.
- UL508 listed, prewired NEMA 4 stainless steel electrical control panel. Field mounted.
- Programmable logic controls.
- Control panel door handle interlock; hinged waterpress cover electrical interlock.
- Electrical specifications:
 - 200/60/3
 - 230/60/3
 - 460/60/3

OPTIONS

- Chute extension, for through the wall discharge.
- Auxiliary base for elevating waterpress.
- Heated chute.
- Flush mounted control panel.
- Buss communication.
- Pulp level detector.

MODEL

- WP-6 – Waterpress

Specifications, Details and Dimensions on Reverse Side.

**WP-6 WATERPRESS**

WP-6 WATERPRESS



701 S Ridge Avenue, Troy, OH 45374
1-888-4HOBART • www.hobartcorp.com

SPECIFICATIONS

WATERPRESS: For squeezing slurry and pumping return water to pulper for re-use, and discharging a semi-dry pulp. Designed to permit removal of helical screw and screen assembly without disconnecting slurry or return water piping.

WATERPRESS MOTOR: 3 H.P., foot mounted, totally enclosed, fan cooled.

RETURN PUMP MOTOR: 5 H.P., heavy duty, foot mounted, totally enclosed, fan cooled. 5 H.P. return pump motor standard, other H.P. available.

RETURN PUMP SET: Includes motor, with stainless steel impeller and mechanical seal to protect stainless steel drive shaft.

Standard pump capable of pumping return water 300 feet horizontally and 15 feet vertically. Depending upon equipment location, pump and motor horsepower may vary from standard.

CONTROLS: Listed, UL508 industrial control panel. Rewired NEMA 4 electrical control panel. Field mounted. Control panel contains a main circuit breaker interlocked with panel door handle and magnetic type nominal 115 volt controls. Panel to include circuit

breakers, magnetic starters, and individual three leg thermal overload protection for each motor.

An electrical interlock is provided to keep the equipment from operating, or to turn off the equipment if the hinged cover on the discharge chute is raised.

WATERPRESS ASSEMBLY: Includes a stainless steel shell, 6 inch diameter gear driven helical screw with attached nylon brush mounted within a perforated cylindrical screen, stainless steel wiper plates to control moisture content of pulp, slurry inlet connection, return water outlet connection and overflow connection. Stainless steel access cover and removable access door included to facilitate cleaning and maintenance.

DISCHARGE HOUSING: Stainless steel, contains gear reducer driven by the 5 H.P. drive motor. Includes stainless steel discharge chute.

WATERPRESS BASE: Structural base consists of tubular steel members with stainless steel flanged feet. Base to support waterpress assembly, discharge housing and return pump set.

VALVES: Motorized and manual 1/2 inch NPT ball valves for system "Pump-Down." Field mounted.

DETAILS AND DIMENSIONS

PLUMBING NOTES

- CUSTOMER TO PROVIDE ALL INTERCONNECTING SLURRY AND RETURN PIPING FROM WATERPRESS TO PULPER(S). ALSO, OVERFLOW LINE AND DRAIN LINES FROM WATERPRESS TO FLOOR SINK OR FLOOR DRAIN.
RECOMMENDED BUILDING FLOWING WATER PRESSURE TO THE PULPER IS 45 PSIG MIN (18 GPM).
IF FRESH WATER SUPPLY PRESSURE IS HIGHER THAN 45 PSIG, A PRESSURE REGULATING VALVE MUST BE INSTALLED IN THE WATER LINE (BY OTHERS).
- RECOMMENDED INTERCONNECTING PIPING TO BE STANDARD TYPE "M" COPPER.
- TERMINATE SLURRY, RETURN AND FRESH WATER LINE WITH UNION OR FLANGE TYPE FITTING.
- ALL CLEANOUTS IN SLURRY AND RETURN LINES MUST BE A "T" OR LATERAL TYPE FITTING. CLEANOUTS TO BE INSTALLED AT ALL TURNS AND EVERY 50'-0" IN STRAIGHT PIPE RUNS. CLEANOUTS TO BE INSTALLED AND MADE ACCESSIBLE.
- AT OFFSETS IN PIPE RUNS, USE LATERAL TYPE FITTING AND MAKE ACCESSIBLE.
- AT JUNCTIONS IN PIPE RUNS, USE A "T-Y" OR LATERAL TYPE FITTING AND MAKE ACCESSIBLE.
- HOT AND COLD WATER HOSE BIBS (FOR DAILY CLEANING OF UNIT), TO BE INSTALLED CLEAR OF BUT ACCESSIBLE TO UNIT WITH A HEAVY DUTY HOSE AND SQUEEZE VALVE. (SUPPLIED BY OTHERS).
- FLOOR DRAIN OR FLOOR SINK, 4" MIN. (ACCORDING TO LOCAL CODE REQUIREMENTS), TO BE KEPT CLEAR OF, BUT ACCESSIBLE TO THE UNIT.
- PROTECT ALL EQUIPMENT AND RELATED PIPING FROM FREEZING TEMPERATURES AND CONDENSATION.
- NO EXTERNAL STRAIN TO BE EXERTED ON HOBART EQUIPMENT.

CONNECTION INFORMATION (AFF - ABOVE FINISHED FLOOR)

- | | |
|----|---|
| E1 | ELECTRICAL CONNECTION - WATERPRESS DRIVE MOTOR |
| E2 | ELECTRICAL CONNECTION - RETURN PUMP MOTOR |
| E3 | ELECTRICAL CONNECTION - CHEMICAL ADDITIVE PUMP |
| E4 | ELECTRICAL CONNECTION - SERVICE SUPPLY 1-3/4" CONDUIT HOLE |
| P1 | DRAIN VALVE OUTLET CONNECTION (PIPE TO FLOOR SINK), 1-1/2" NPT (MALE), 25" AFF. |
| P2 | RETURN WATER OUTLET CONNECTION, 1-1/2" NPT (MALE), 25" AFF. |
| P3 | SLURRY INLET CONNECTION, 4" NPT (MALE), 27" AFF. |
| P4 | FRESH HOT WATER INLET CONNECTION, 3/4" NPT (FEMALE), 16" AFF. |
| P5 | OVERFLOW CONNECTION, (PIPE TO FLOOR SINK, DO NOT REDUCE) 3" NPT (MALE), 30-5/16" AFF. |

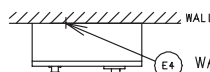

WALL MOUNTED CONTROL BOX
(ELECTRICAL CONDUIT HOLES TO BE ADDED AT TIME OF INSTALLATION)

GENERAL NOTES

- ELECTRICAL CONTROL PANEL, BY HOBART, SHOULD BE LOCATED WITHIN SIGHT OF WATERPRESS AND BE EASILY ACCESSIBLE.
- APPROXIMATE SHIPPING WEIGHT: 600 LBS.
- OVERALL CRATE SIZE: 82"W X 44"L X 48"H. MAX (59 CU. FT.)

VOLTAGE	WATERPRESS MOTOR AMPS	5.0 HP RETURN PUMP MOTOR AMPS
208/60/3	8.5	12.6
230/60/3	8.2	12.0
460/60/3	4.1	6.0

WARNING

ELECTRICAL AND GROUNDING CONNECTIONS MUST COMPLY WITH THE APPLICABLE PORTIONS OF THE NATIONAL ELECTRICAL CODE AND/OR OTHER LOCAL ELECTRICAL CODES.
PLUMBING CONNECTIONS MUST COMPLY WITH APPLICABLE SANITARY, SAFETY AND PLUMBING CODES.

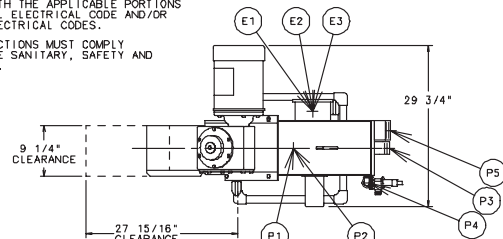

ELECTRICAL NOTES

- ELECTRICAL CONTROL PANEL IS A SURFACE MOUNTED ENCLOSURE (AVAILABLE IN NEMA 4 (SST), WATERPRESS-(24 X 20 X 8)).
- EACH ELECTRICAL CONTROL PANEL IS PREWIRED FROM THE FACTORY AND CONTAINS THE FOLLOWING ITEMS:
(A) MAIN CIRCUIT BREAKER (THERMAL MAGNETIC) INTERLOCKED WITH DOOR HANDLE.
(B) MAGNETIC CONTROLLER WITH OVERCURRENT PROTECTION FOR EACH MOTOR.
(C) STEP-DOWN TRANSFORMER FOR 115 VOLT (NOMINAL) CONTROL CIRCUIT OPERATION.
(D) ALL CONTROLS DESIGNED TO MEET THE REQUIREMENTS OF UL-508
- CONTROL CIRCUIT TO BE 115 VAC NOMINAL
- ALL CONTROL PANELS ARE TO BE WIRED IN ACCORDANCE TO LOCAL, STATE AND/OR NATIONAL ELECTRIC CODE SPECIFICATIONS
- REMOTE PUSHBUTTON STATION TO BE MOUNTED & WIRED AT WORKSTATION BY OTHERS. (BRACKET SUPPLIED BY OTHERS)
- REMOTE PUSH BUTTON STATION HOUSES TWO (2) ILLUMINATED PUSH BUTTONS.
- EQUIPMENT DRIVE MOTORS ARE PROVIDED AS FOLLOWS:
(A) RECIRCULATING PUMP MOTOR IS TOTALLY ENCLOSED, FAN COOLED.
(B) WATERPRESS MOTOR IS TOTALLY ENCLOSED, FAN COOLED.
- CUSTOMER TO PROVIDE ALL INTERCONNECTING WIRING FROM PREWIRED ELECTRICAL CONTROL PANEL TO PREWIRED TERMINAL BLOCKS. ELECTRICAL WIRING DIAGRAM PROVIDED WITH EACH WATERPRESS.

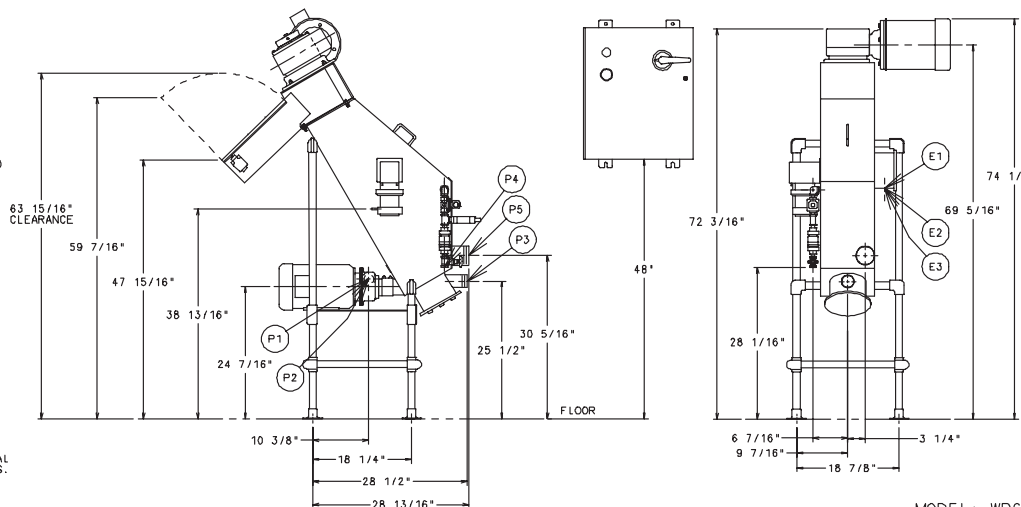

As continued product improvement is a policy of Hobart, specifications are subject to change without notice.

MODEL: WP6
OPERATION
E-316139
REV. B